



Engineered 1/2" (13 mm) and 3/4" (19 mm) platforms Installation Guide



It is **important** to read the Installation Guide, Maintenance Guide, and Mercier Warranty **before** installing your prefinished wood floor. **Failure to follow the installation instructions may void your warranty.**

For questions about installation, please contact your authorized Mercier dealer or Mercier's Technical Service at 1-866-448-1785 or technicalservice@mercierwoodflooring.com.

Product description

Mercier prefinished Engineered 1/2" (12.7 mm) and 3/4" (19 mm) wood flooring consist of a hardwood surface glued to premium hardwood plywood. They are specially designed for installation in all situations, including in basements and over radiant heating systems¹ and concrete subfloors.

Prefinished flooring is factory finished under controlled, optimal conditions. The flooring is ready to install and occupants are not required to leave the premises.

Recommended use



Installation sites

- 1st story : Yes
- Ground floor : Yes
- Basement : Yes



Radiant heating systems

Engineered flooring is recommended for use over radiant heating systems, except for Hickory.

Owner and installer responsibilities

Prior to installation, the installer and owner must ensure the installation site and subfloor comply with the conditions specified in this guide.

The installer and owner should inspect the flooring before installation to ensure the grade, color, gloss, and quality are consistent with the product purchased.

Mercier products meet stringent quality requirements and top industry standards. The industry standard margin of error for natural imperfections and manufacturing and grade selection defects is 5%.

If the installer has doubts about a board's grade selection or manufacturing or finish quality and cannot install it in an inconspicuous location or eliminate the imperfection, he should not install it.

Once a board has been installed, it is considered to have been accepted by the installer and the owner, even if the owner is not present during installation.

Depending on the site and the type of installation², flooring orders should include 3% to 5% extra to compensate for cut loss.

Mercier Wood Flooring only replaces products with a defect rate that exceeds 5% (excluding the 3% to 5% cut loss). Mercier cannot be held liable for improper installation or poor judgement by an installer. It does not cover labor or installation costs.

¹See Technical Bulletin #5 at mercierwoodflooring.com for specifications for use over radiant heating systems.

²Diagonal installation results in increased cut loss of up to 7% to 9%.

Warning!

Authentic grade Mercier flooring has specific characteristics that may be apparent at purchase or appear over time, including:

- Cracked or sagging finish around character marks
- Open knots and holes (including worm holes)
- Splits and checks
- Character marks that may become more prominent
- Open markings that may sag

Recommended materials and tools

This is not an exhaustive list of the tools that may be needed to install your Engineered wood floor. You will need additional equipment depending on the type of installation you choose. See Additional equipment below. Mercier Wood Flooring is not responsible for damage caused by improper use of tools.

1. Vacuum or broom
2. Mitre saw
3. Measuring tape
4. Chalk line
5. Square
6. Handsaw
7. Hammer and tapping block
8. Levelling compound and sander
9. Slip tongue and wood glue (as needed)
10. Mercier Touch-Up Kit
11. Mercier Maintenance Kit

Additional equipment for glued installation

- Waterless, urethane-based adhesive
Recommended adhesives:
 - Finitect AcoustiTECH AD-532+ / AD-844 MS
 - Titebond 811 Advantage
 - Bostik's BEST, EFA+, or BST
- Trowel recommended by the manufacturer of the adhesive
- 3M blue masking tape or equivalent
- Guide strips and concrete nails (to support and attach the first row)
- 100 lb. to 150 lb. (45 kg to 68 kg) roller
- Urethane-based adhesive cleaner
- AcoustiTECH Leed 3.3 acoustical membrane* (or equivalent with a maximum thickness of 5 mm, ≥ 2 psi, and 25% compression or a maximum thickness of 5 mm to 8 mm, ≥ 5 psi, and 25% compression)

*Using a thicker membrane or one with greater compression can result in increased vertical movement.

Additional equipment for nailed or glued installation

- Hardwood flooring nailer or stapler (pneumatic or manual)
- Drill and $\frac{3}{32}$ " (2.38 mm) bit
- Nail punch and spiral finishing nails between 1 $\frac{1}{2}$ " (38 mm) and 2 $\frac{1}{2}$ " (63 mm) in length, depending on the thickness of the floor
- Floor screws

See Technical Bulletin #9 for recommended fasteners at mercierwoodflooring.com

Additional equipment for floating installation

Recommended adhesive and membrane:

- PVA Type II wood glue
- AcoustiTECH VP acoustical membrane* (or equivalent with a maximum thickness of 3.5 mm, ≥ 5 psi, and 25% compression)

Preparing the installation site

Installing prefinished wood flooring should be the last step in your project. Before the flooring is delivered, inspect the installation site to make sure:

- The concrete, plaster, paint, and subfloor are completely dry.
- Any heating, ventilation, or air conditioning systems are functional and running.
- The building is kept within normal ambient conditions for at least one (1) week before laying the floor, at a temperature of about 20 °C (68 °F) and a relative humidity of about 45%.

The installer should check the moisture content of the subfloor (plywood or OSB) and flooring at various locations using a moisture meter for wood.

The moisture content of the subfloor should not exceed 12%. The difference between the moisture content of the subfloor and the flooring must not exceed the internal moisture content of the flooring by more than 4%. The internal moisture content of the flooring should be between 6% and 9%.

For boards wider than 4" (102 mm), the difference between the moisture content of the subfloor and the flooring must not exceed the moisture content of the flooring by more than 2%. The internal moisture content of the flooring should be between 6% and 9%.

If the humidity of the subfloor or the difference between the flooring and the subfloor is outside recommended levels, heat, ventilate, and dehumidify the site further and delay delivery and installation until recommended levels have been reached.

If the subfloor is a concrete slab, allow a minimum 30-day drying period for a reliable moisture-level test. Measurements should not exceed 4% using a concrete moisture meter. If there is moisture, test using calcium chloride. The moisture content measured with the calcium chloride test should not exceed 3 lb. per 1,000 sq. ft. over 24 hours.

Acclimation

Once the recommended conditions have been reached, store the flooring at the installation site. Allow the flooring to acclimate for at least 24 hours before installation. Make sure the wood is at the same temperature as the installation site (about 20 °C (68 °F)). Never store flooring in unsuitable locations such as sheds or unheated garages.

Subfloor preparation and levelling

- The subfloor must be structurally sound and securely fastened to the joists with floor screws to prevent movement of the plywood panels, which could cause creaking.
- **The subfloor must be flat and level. The maximum tolerance is $\frac{5}{32}$ " (4 mm) over a distance of 8' (2.4 m) for a floating installation and $\frac{3}{16}$ " (5 mm) over a distance of 10' (3 m) for nailed and stapled installations.** If necessary, fill or sand any unevenness, depression or bulge in the subfloor.
- The surface of the subfloor must be free of defects. Remove minor imperfections with a sander.
- The surface must be clean and free of all contaminants, including grease, dust, oil, nails, staples, etc. Remove staples, drive in protruding nails, and remove dirt and dust with a vacuum cleaner.

For installation on a concrete subfloor, make sure the concrete is not low density (below 3,000 psi) or brittle.

For installation on a wood subfloor, make sure the structure meets the following requirements:

- $\frac{3}{4}$ " (19 mm) plywood or oriented strand board (OSB) for joists spaced $19\frac{3}{16}$ " (488 mm) or less on centre
- Minimum $\frac{5}{8}$ " (16 mm) plywood panels for joists spaced 16" (406 mm) or less on centre.

Recommended installation method

- Plan your project by making a sketch.
- Determine your start point.
- Determine the direction of the flooring. We strongly recommend installing flooring at a 45- or 90-degree angle with respect to the floor joists on wood subfloors.
- Use a protective surface under tools and the floor nailer during installation.
- Before you begin, cut the bottoms of door moldings to insert flooring under them.
- Leave space for the wood to expand as a result of humidity changes. The expansion gaps will be hidden by the baseboard and/or quarter round, which should be nailed to the wall, not the floor.
- Pick boards from at least 3 boxes at a time to ensure consistency.
- Vacuum frequently during installation to remove sawdust and dirt.

Installation

Glued installation

For Engineered ½" (13 mm) and ¾" (19 mm) flooring.

Mercier Engineered wood floor can be glued directly to concrete or wood subfloors in basements, ground floor and above.

If you are using an acoustical membrane, it must be glued to the subfloor before installing the flooring.

Warning!

During installation, immediately wipe up any adhesive from the floor surface with adhesive cleaner.

How to install flooring

- Use a chalk line to snap a guide line parallel to the starting wall at a distance of ¼" (6 mm) more than the width of the boards (e.g., 5 ¼" (133 mm) for flooring that is 5" (127 mm)). Flooring in the area between the wall and the guide line should be installed last.
- Make sure your line is straight and square.
- Lay out 4 or 5 rows of boards that match in terms of joints and color. Cut boards with imperfections or install them in less visible areas.
- Nail the guide strips along the start line. The first row of boards will butt up against them.
- Use the trowel to apply adhesive at a 45-degree angle outward from the start line. It is important to use the trowel recommended by the manufacturer in order to apply the correct amount of adhesive.
- Install the first board along the guide line, with the groove towards you and the tongue towards the wall. Always leave a ¼" (6 mm) gap on either side of each row for expansion.
- Lay the floor in small sections to prevent the adhesive from drying.
- Install the remaining boards in the row from left to right.
- The last board in the row should be cut. Offcuts that are at least 6" (152 mm) long can be used to start the next row. For subsequent rows, insert the tongue into the groove and push it as close as possible to the adjacent board, being careful not to touch the adhesive. You may need to use a tapping block to get the tongue into the groove.
- Use blue masking tape every 5 or 6 rows to ensure the flooring stays in place.
- Use a 100 lb. to 150 lb. (45 kg to 68 kg) roller to apply pressure to installed sections while the adhesive is still active (45 to 60 minutes). Cover the roller to avoid damaging the floor.
- Repeat these steps for the entire floor.
- For best results, stagger joints 6" to 8" (152 mm to 203 mm) between rows and alternate board lengths.
- Once the rest of the floor is finished, remove the guide strips and install flooring in the remaining space.
- You may have to rip the last row lengthwise to allow a ½" (13 mm) expansion gap.
- Wait 24 hours before replacing furniture and allowing traffic on the floor.

Nailed or stapled installation

For Engineered ½" (13 mm) and ¾" (19 mm) flooring.

Mercier Engineered wood floor can be nailed or stapled directly to wood subfloors in basements, ground floors and above.

Using a nailer

- Practice using your floor nailer on a scrap piece of flooring. Follow the manufacturer's instructions and safety guidelines.
- Clean the plate under the nailer frequently to avoid damaging the finish.
- Adjust the pressure on the compressor and check it regularly.

How to install flooring

- Use a chalk line to snap a guide line parallel to the starting wall at a distance of ½" (13 mm) more than the width of the boards (e.g., 5 ½" (140 mm) for flooring that is 5" (127 mm) wide). Flooring in the area between the wall and the guide line should be installed last.
- Make sure your line is straight and square.
- Lay out 4 or 5 rows of boards that match in terms of joints and color.
- Cut boards with imperfections or place them in less visible areas.
- Use spacers or shims between the edge of the flooring and the walls to leave enough room for the wood to expand due to changes in humidity.
- Install the first board along the guide line, with the tongue towards you and the groove towards the wall.
- Always leave a ¼" (6 mm) gap on either side of each row for expansion.
- Nail the first row by hand. Drill holes at a right angle to the top of the board as close as possible to the wall and fasten with spiral finishing nails. Drive in the nail heads with a nail punch. Drill holes in the tongue at a 45-degree angle and drive in spiral nails. (see Image 1)
- The last board in each row should be cut. Offcuts that are at least 6" (152 mm) long can be used to start the next row.
- Use a manual or pneumatic nailer for subsequent rows. Boards should be nailed every 4" to 6" (102 mm to 152 mm) and 2" (51 mm) from either end. Each board must be secured with at least two nails. Do not nail closer than 2" (51 mm) from the ends to avoid splitting the tongue. See the Fastener Selection Chart below from Technical Bulletin #9 for full details.

Fastener Selection Chart

Platforms and thicknesses	Widths	"L" or "T" nails	"U" staples	Fastener's minimum length	Spacing between fasteners	Distance from ends
Engineered ½" (13 mm)	5" (127 mm) 6 ½" (165 mm)	18 ga to 20 ga	18 ga	1 ¼" (32 mm)	4" to 6" (102 to 152 mm)	2" (51 mm)
Engineered ¾" (19 mm)	5" (127 mm)	15 ga to 17 ga	15 ga to 17 ga	1 ½" (38 mm)	4" to 6" (102 to 152 mm)	2" (51 mm)
Engineered ¾" (19 mm)	6 ½" (165 mm) 8 ½" (206 mm)	15 ga to 17 ga	Not recommended	1 ½" (38 mm)	4" to 5" (102 to 127 mm)	2" (51 mm)
Engineered ¾" (10 mm)	3 ¼" (83 mm)	18 ga to 20 ga	18 ga	1" (25 mm)	4" to 6" (102 to 152 mm)	2" (51 mm)

- Fasteners must be installed at a 45-degree angle. (see Image 2)
- You may need to use a tapping block to fit the boards together. NEVER use a hammer or a sledgehammer directly on the boards.
- For best results, stagger joints 6" to 8" (152 mm to 203 mm) between rows and alternate board lengths.
- The use of urethane-based glue is recommended in addition to nailing for flooring that is 6 ½" (165 mm) and 8 ½" (206 mm) wide. Apply a trowel width of adhesive perpendicular to the direction of the flooring every 20" (508 mm) or so. (see Image 3)
- The last rows of boards should be installed in the same manner as the first.
- You may have to rip the last row lengthwise to allow a ½" (13 mm) expansion gap.

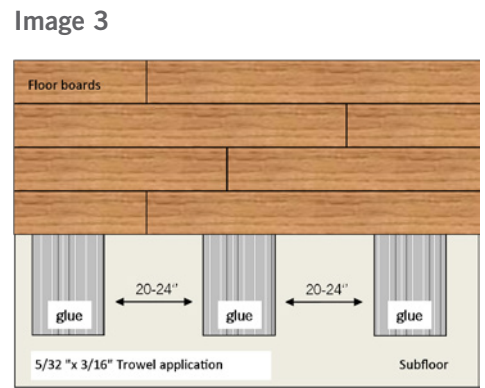
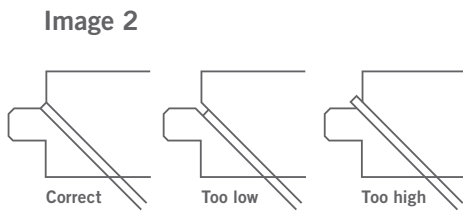
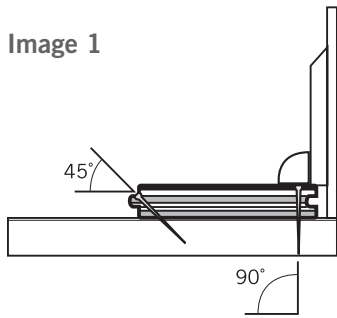

Warning!
Split or broken tongues can cause creaking. When working with harder woods, it's important to pay close attention to the pressure on the compressor.

Floating installation

For Engineered 1/2" (13 mm) and 3/4" (19 mm) flooring.

With the exception of 6 1/2" (165 mm) x 1/2" (13 mm) Hickory, Mercier Engineered wood floors can be installed as a floating floor on concrete and wood subfloors in basements and on ground floors and above, as long as you follow the installation instructions.

How to install flooring

- The floor should not be attached to any surface. Expansion gaps are required for all fixed elements. See Table 1 below for the recommended expansion gap based on the dimensions of the room.

Table 1

Expansion gap	Maximum room width	Maximum room length
1/2" (13 mm)	26' (8 m)	52' (16 m)
3/4" (19 mm)	40' (12 m)	80' (24 m)

- When the room dimensions exceed the above values, use a T-molding.
- Install the acoustical membrane over the entire subfloor in the opposite direction to the flooring (see the installation instructions for the acoustical membrane).
- The first rows of flooring are the most important. They must be straight and all joints must fit perfectly.
- Install the first board along the line, with the tongue towards you and the groove towards the wall. Always leave a 1/4" (6 mm) expansion gap on either side of each row for expansion. If the walls aren't square, use wedges or shims between the flooring and the wall in order to keep an expansion gap.
- Carefully apply a smooth, even ribbon of glue at least 1/16" (1.6 mm), but not exceeding 1/8" (3 mm) on the bottom of the groove only. (see Image 4)

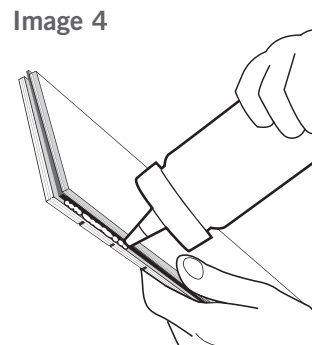

Warning!
It is very important to follow the gluing instructions. If the glue is applied incorrectly or you don't apply enough, the joint could separate. Too much glue will make the job unnecessarily difficult. You should never apply glue to the tongue and groove at the end of the board.

- Install the remaining boards in the row from left to right.
- Wipe off any excess glue immediately with a dry cloth.
- The last board in each row should be cut. Offcuts that are at least 6" (152 mm) long can be used to start the next row.
- Continue in this manner for the entire floor.
- You may need to use a tapping block to fit the boards together.
- For best results, stagger joints 6" to 8" (152 mm to 203 mm) between rows and alternate board lengths.
- It is sometimes necessary to use blue 3M tape to hold the flooring in place while the glue dries.
- Rip the last row of boards to width and allow for an expansion gap.

Installation over a radiant heating system

Suitable for a nailed, stapled or floating installation. Refer to the radiant heating system manufacturer's recommendations for more information. With the exception of Hickory, Engineered flooring may be used over a radiant heating system in basements, ground floors, and subsequent storeys by following these instructions. See Technical Bulletin #5 on flooring over radiant heating systems at mercierwoodflooring.com for more information.

Precautions and recommendations:

Engineered flooring **MUST** be attached to the subfloor when used with radiant heating systems.

- The system must be tested and turned on a few weeks before installing the floor.
- Turn the system off during installation.
- Floors with radiant heating systems should not exceed 27 °C (80 °F) while in use.
- Visible or exposed pipes must be covered with $\frac{3}{8}$ " (10 mm) plywood or a layer of concrete to ensure uniform heat distribution.
- When turning radiant heating on or off at the beginning or end of a season, gradually increase or decrease the temperature to limit stress on the wood.

You may need to install stair nosings, T-moldings, quarter-rounds, or reducers. These moldings are available in the same colors and species as your Mercier floor, and are available from your authorized Mercier dealer. Order them at the same time as your flooring.

Before installing the flooring, we recommend selecting boards that blend well with your moldings to avoid sharp contrasts in the floor's appearance.

Warning!

We recommend pre-drilling pilot holes in the moldings to avoid splitting them.

When installing moldings such as baseboard and quarter round, make sure to attach them to the wall, not the wood floor, to allow for movement.

Always leave the recommended space for expansion.

Inspection, finishing, and maintenance

When installation is complete, vacuum the floor and clean it with Mercier Cleaner according to the instructions. NEVER use large amounts of water to clean a hardwood floor.

Use the Mercier Touch-Up Kit to fill and conceal small nail holes. For more information, see Technical Bulletin #7 on the Touch-Up Kit at mercierwoodflooring.com.